



# Case Study

## SPLIT COOLING FANS

Some years ago John Welsh Gearboxes had a cooling fan on the main drive shaft that had failed and needed urgent replacement. Morse designed and fabricated a split fan instead of the standard single piece arrangement. This was a far cheaper option as it enabled the impeller to be fitted without removing the drive motor, weighing many tonnes, re-fitting and then re-aligning.

More recently we have been incorporating our knowledge of low noise motor cooling fans and providing the option for a split low noise cooling fan for large gearboxes/reducers. ie; two problems solved with one cooling fan.

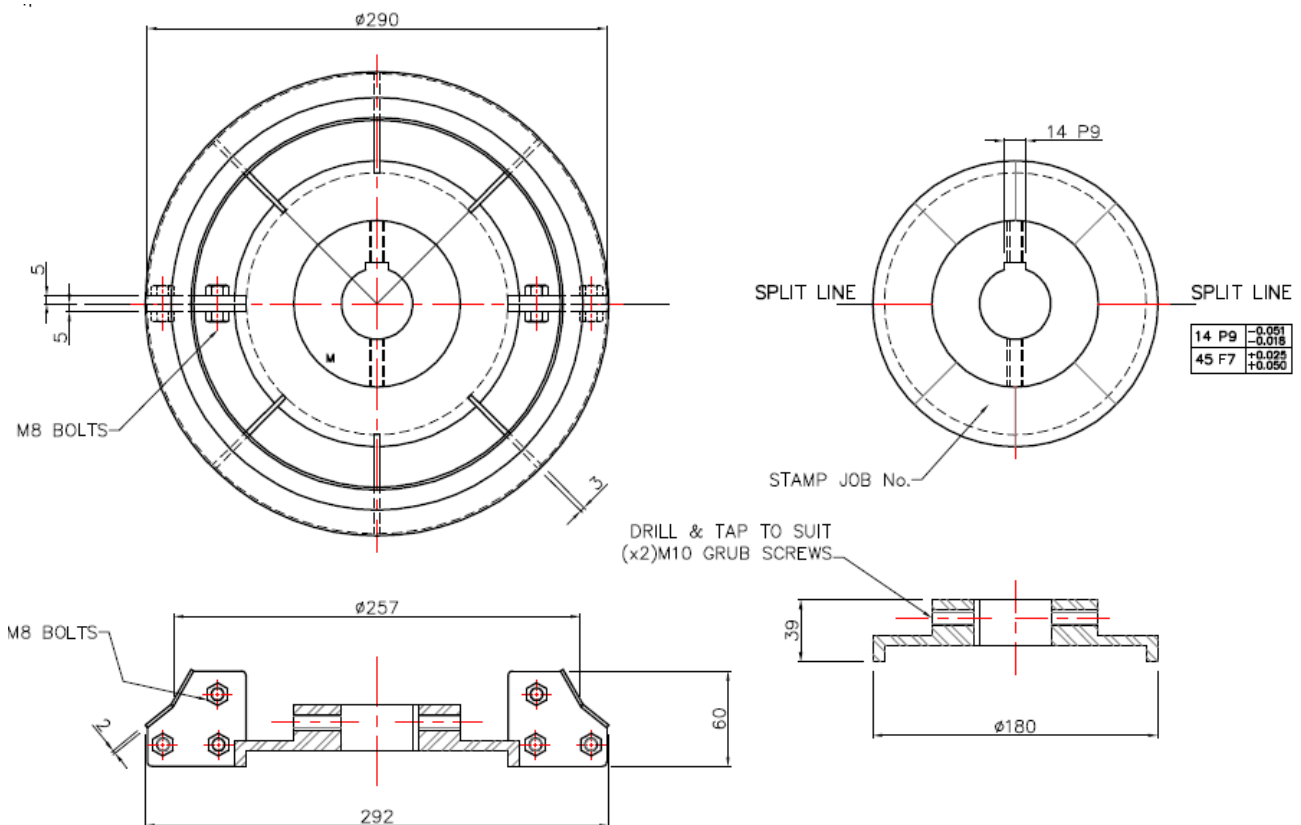

**MORSE**  
Air Systems

5 Dempster Street, Ferntree Gully, Victoria 3156  
Phone: (03) 9758 7733 Fax: (03) 9758 2366  
Email: sales@morseairsystems.com.au  
[www.morseairsystems.com.au](http://www.morseairsystems.com.au)  
[www.morselownoisefans.com.au](http://www.morselownoisefans.com.au)



**MORSE**  
Low-Noise Fans